

Part number
CMO 16



Brief description:

hoods for two levers, size "104.27" insulated 830V version, side entry, Pg21, insulated 830V version, IP66

Product description	
Version	insulated 830V version
Series	Hoods with 4 pegs
Product type	with 4 pegs
Variant	side entry
Family	830V enclosures for CME inserts
Size	size "104.27" insulated 830V version
Technical data	
Material	metal
IP degree of protection	IP66 (and IP69K DIN 40050 - 9)
Cable entry	Pg21
Further technical details	
Weight	208,00 g

Approvals / Standards	
Quality mark	UL (type:4/4X/12), CE, EAC
Conformity	CQC, CE
General ordering information	
EAN13 code	8015747031158
Tariff number	85369095
Packaging Information	
Packaging length	255,00 mm
Packaging height	150,00 mm
Packaging width	180,00 mm
Packaging weight	2,08 kg
Packaging volume	6,89 dm ³
Packaging description	Carton box
Packaging quantity	10 Pcs
Packaging EAN code	8015747233828
Sub-packaging weight	1,04 kg
Sub-packaging description	Carton Box
Sub-packaging quantity	5 Pcs
Sub-packaging EAN barcode	8015747031165

Part number

CMO 16



Catalogue drawings

**CMO [CMAO] CMV (CMAV) - MMO [MMAO]
MMV (MMAV)**

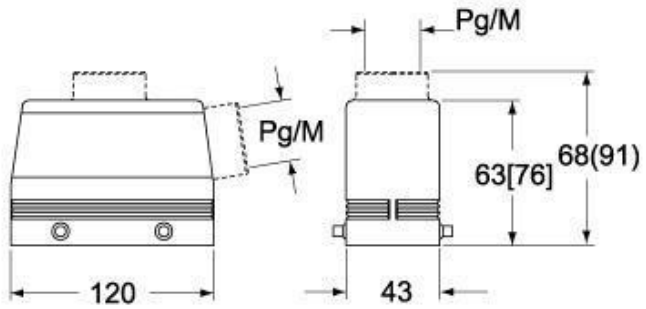

CMV G (CMAV G) - MMV G (MMAV G) - [MMFV G]

